

F5 WANJet™ 200 Appliance

Quick Start Card

How to get started with the WANJet 200 appliance



Overview

This Quick Start Card describes how to install the F5 Networks WANJet™ 200 appliance.



1 Before you begin

Gather the following information from your network administrator:

- IP address and corresponding netmask for the WANJet appliance. The IP address must be in the same subnet as the WAN router that connects directly to the WAN port on the WANJet appliance.
- IP address of the WAN router (WAN gateway).
- Optional: IP address for the Management port if you are using out-of-band management and an Ethernet cable to connect to the management network.

2 Check package contents

The WANJet 200 shipping box includes the following parts:

- WANJet 200 appliance
- Power cord
- Blue CAT-6 Ethernet cable
- External power supply
- Yellow CAT-5e crossover cable
- Beige console cable

Unpack the box and verify that all items are included. If parts are missing, contact F5 Networks Technical Support.

CAUTION:

The power cord included with the WANJet appliance is for exclusive use with the WANJet appliance. Do not use this power cord with other electrical appliances.

3 Power up the WANJet 200 appliance

There is no power button on the WANJet 200 appliance. To power up the WANJet appliance, perform the following steps.

1. Plug the power cord into the external power supply on the back of the WANJet appliance.
2. Plug the external power supply into a power outlet.
The WANJet appliance starts up automatically.

4 Set the addresses

The WANJet appliance is shipped with the following default values:

- IP address **192.168.168.100**
- Subnet mask **255.255.255.0**

Important

The following instructions are for a PC with Windows® XP installed. If the computer or laptop that you are using to access the WANJet appliance is currently connected to your corporate LAN, you must remove the corporate LAN cable from the computer before proceeding.

To attach a computer to the WANJet appliance

1. On a computer or laptop, plug the yellow CAT-5e crossover cable into the Ethernet port.
2. Plug the other end of the yellow CAT-5e crossover cable into the LAN port on the back of the WANJet appliance.
3. From the attached computer's Start menu, choose Control Panel.
4. Click the **Network and Internet Connection** icon then click **Network Connections**. A new window opens with a list of network connections.
5. Click the network connection (likely a local area connection) that corresponds to the port to which you connected the Ethernet cable in step 1. The Local Area Connections Properties dialog box opens.
6. On the General tab, click **Properties**. The **Local Area Connections Properties** dialog box opens.
7. In the box that reads **This connection uses the following items**, select **Internet Protocol (TCP/IP)** and click **Properties**.
8. On the General tab, select the option **Use the following IP address**.
9. Into the **IP address** box, type **192.168.168.175** or an address in the same subnet as the WANJet appliance default IP address (**192.168.168.100**).
10. Into the **Subnet mask** box, type **255.255.255.0**.
11. Click **OK** when you are done, then click **OK** again to dismiss the Local Area Connections Properties dialog box.

To set WANJet appliance addresses from the attached computer

1. Open a web browser.
2. Connect to the WANJet appliance using the default address. In the address bar, type **https://192.168.168.100:10000** and click **Go**.
3. If you see a Security Alert dialog box, click **Yes**. The WANJet appliance login screen opens.

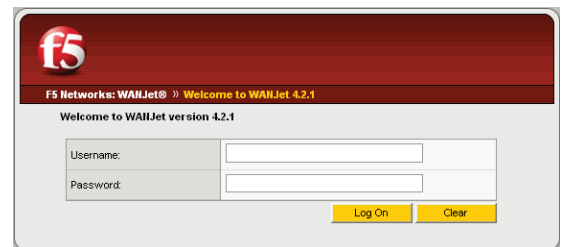

4. Type the user name and password (the defaults are both **admin**) and click **Log On**. The WANJet appliance Web UI opens.
5. In the navigation pane, expand **Configuration** and click **Local WANJet**. The Local WANJet screen opens.
6. Configure the local WANJet appliance by typing the following information:
 - After **WANJet Alias**, type a name for the WANJet appliance.
 - After **WANJet IP**, type the IP address for the WANJet appliance (default: **192.168.168.100**).
 - After **WANJet Netmask**, type the netmask for the WANJet appliance (default: **255.255.255.000**).
 - After **WAN Gateway**, type the default WAN gateway for the WANJet appliance (default: **192.168.168.001**).
7. Use the defaults for the other values. If using a separate subnet for management, you can optionally specify addresses for the **Management IP**, **Management Netmask**, and **Management Gateway**. When you finish, click **Save**.
8. Unplug the yellow CAT-5e cable from both the computer and the WANJet appliance.

5 Cable the WANJet 200 appliance

1. Connect the blue Ethernet CAT-6 cable to the LAN port on the back of the WANJet appliance. Connect the other end to your LAN switch.
2. Connect the yellow CAT-5e crossover cable to the WAN port on the back of the WANJet appliance. Connect the other end to your WAN router.

Note that the yellow CAT-5e cable now connects to a different port than it did when initially attaching the computer to the WANJet appliance.

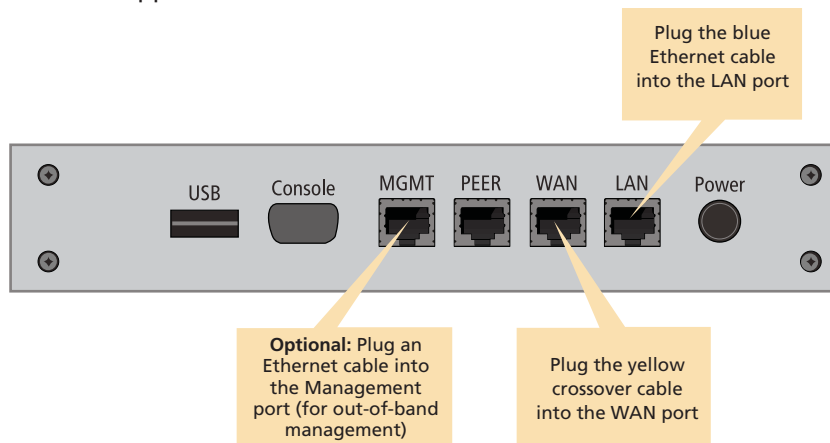

3. Verify that the link LEDs on the front panel of the WANJet appliance are lit for the LAN port and the WAN port. If these lights are not lit, and you have verified that the cables are firmly connected, contact your network administrator.

6 Log on to the WANJet 200 appliance

Finally, check that you can log on to the appliance remotely by using the Web UI, and activate the license.

To log on

1. In a web browser, go to **https://<WANJet IP address>:10000**. (If you set up the Management port, use the **Mgt IP Address** instead.) The WANJet appliance login screen opens.
2. Type the user name and password (the defaults are both **admin**), and then click **Log On**. The Web UI opens and displays the WANJet Status screen.
3. Click **Next**. The EULA (End User License Agreement) screen opens.
4. Read the EULA, and then click **Accept** if you agree to the conditions. When license activation is complete, the WANJet License Details screen opens and shows the current license date.

To activate the license

1. In the WANJet Status screen, click the **Not entered** link, next to **License**, to display the WANJet License Details screen.
2. Next to **Base Registration Key**, you should see your registration key (filled in at the factory).

Note: If automatic license activation does not work, you can use manual activation instead. On the WANJet License Details screen, next to **Activation Method**, select **Manual** and follow the directions on the screen.

Next, you can complete the configuration of the WANJet appliance including changing the default password, specifying remote WANJet appliances, and setting up optimization, IT service, and QoS policies. See the **WANJet Appliance Administrator Guide** for details.

